

**American Polysteel PS 4845-1S** Scale 1.5"=12.0"

**FRONT ELEV,**

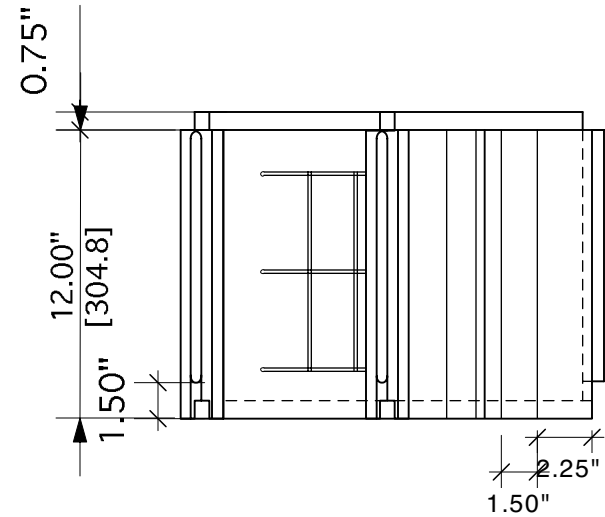

**SECTION**

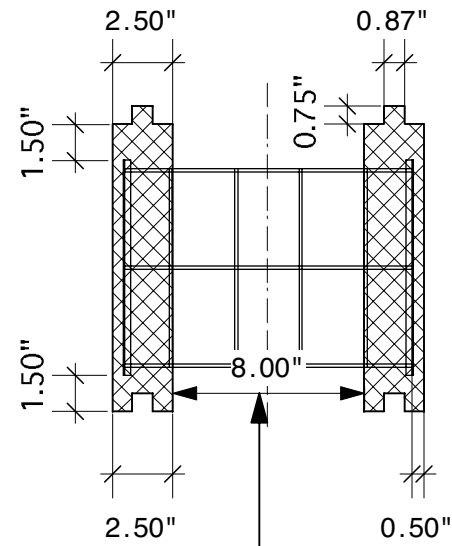

**END ELEV,**

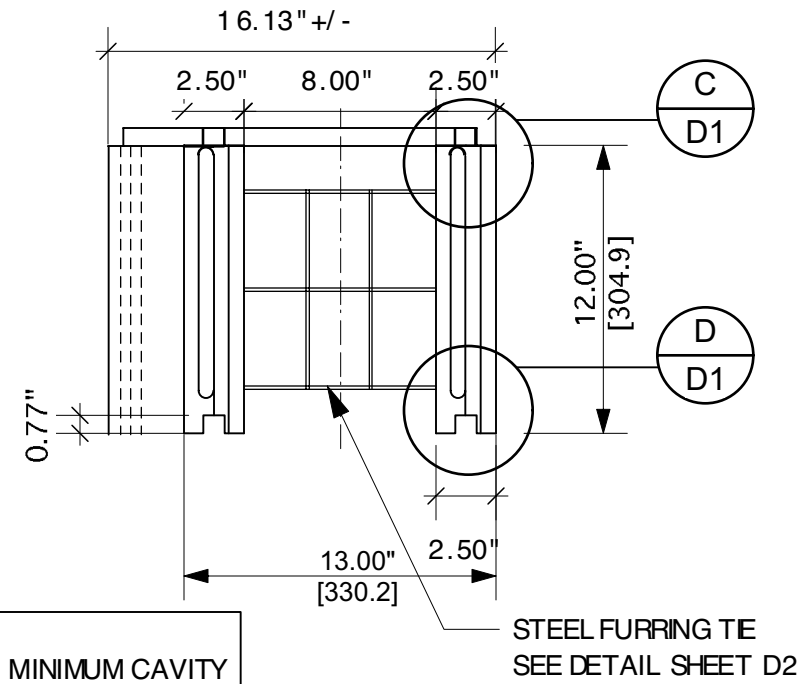

**NOTE:**  
8" (203.2 mm) MINIMUM CAVITY

**PLAN - SHORT 45° CORNER**

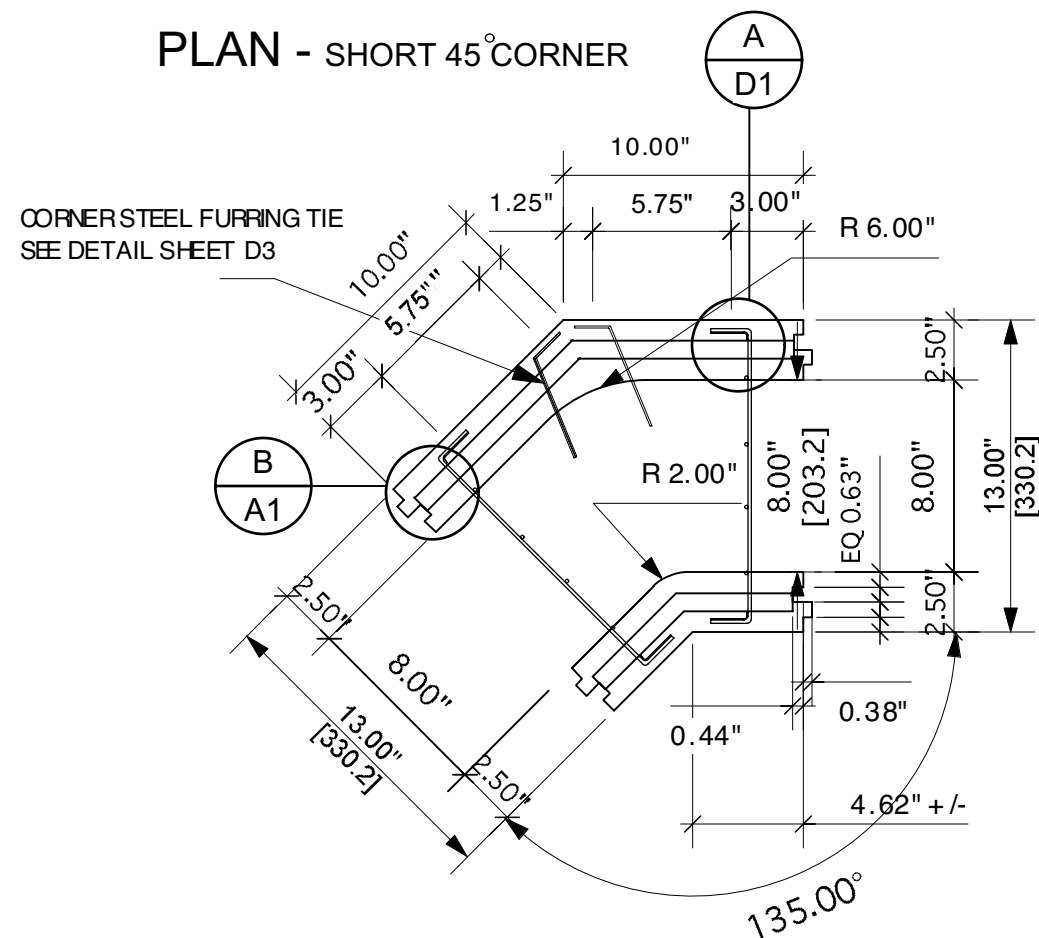

CORNER STEEL FURRING TIE  
SEE DETAIL SHEET D3

**SKETCH OF END TONGUE & GROVE**

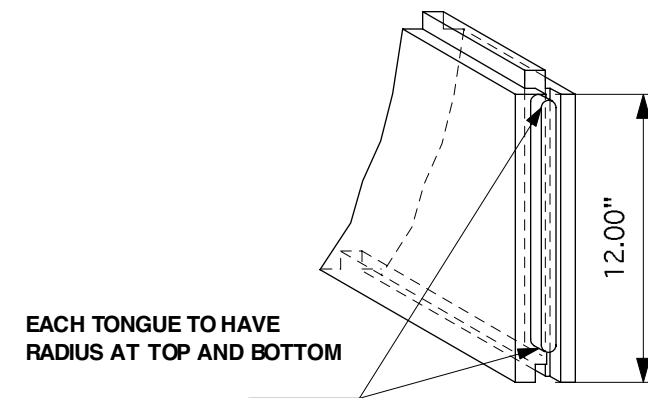

← **END ELEV,**

**NOTE;**  
SEE POLYSTEEL DETAIL SHEETS (D1-D3) FOR  
ADDITIONAL INFORMATION

<b>American Polysteel PS 4845-1S</b>		
SCALE: 1.5"=12.0"	APPROVED BY:	DRAWN BY: AMH
DATE: Mar 2002		REVISED:
Copyright 2002	DRAWING NUMBER:	
American Polysteel 1-800-977-3676	<b>PS 4845-1S</b>	